



**YANGZHOU YANGJIE
ELECTRONIC TECHNOLOGY**

КАТАЛОГ

 www.platan.ru
ПЛАТАН



Официальный
дистрибьютор

О компании



Yangzhou Yangjie Electronic Technology Co., Ltd

Профессиональный сертифицированный разработчик и производитель полупроводниковых компонентов: диодных мостов, диодов, чипов и IGBT модулей.

Продукция YJ (Yangjie Electronic) производится на 3 заводах.

Общая производственная площадь компании составляет 120 000 м².

Число сотрудников – 1000 человек.

Оборот компании составил 173 миллионов долларов US (по данным за 2016 год).

Основная часть производства приходится на диоды и диодные мосты, которые в совокупности представляют свыше 50 серий и более 1,5 тыс. наименований изделий.

Срок производства от 1 до 8 недель в зависимости от объема заказа. Поддержка складских запасов на популярные диоды и диодные мосты.

Заводы оснащены автоматическими линиями.

Продукция YJ (Yangjie Electronic) не содержит вредных и токсичных веществ и соответствует требованиям RoHS и REACH.



YJ (Yangjie Electronic) успешно сотрудничает с компаниями: CITIZEN, SHARP, PHILIPS, MURATA, PANASONIC, TE CONNECTIVITY, FOXCONN и др.

Высочайшее качество товаров, инновационный подход, клиентоориентированность и надежность позволяют считать компанию Yangjie Electronic одним из лучших в мире производителей и поставщиков полупроводниковых компонентов.

Продукция

Полупроводниковые компоненты Yangjie Electronic широко применяются в автомобильной электронике, в производстве бытовой техники, в современных силовых цепях UPS (ИБП), в усилителях, приёмниках, передатчиках, генераторах, измерительных приборах, импульсных схемах и во многих других устройствах.

Полупроводниковые компоненты Yangjie Electronic

- Выпрямительные диоды
- Быстровосстанавливающиеся диоды
- Высокоэффективные диоды
- Ультрабыстродействующие диоды
- Супербыстродействующие диоды
- Диоды Шоттки
- Защитные диоды (Супрессоры)
- Стабилитроны
- Высокочастотные переключающие диоды
- Динисторы и тиристоры

Сертификаты Yangzhou Yangjie Electronic Technology Co., Ltd

Yangjie Electronic имеет сертификаты международных стандартов качества ISO9001, ISO14001, также продукция Yangjie Electronic сертифицирована для использования в автомобильной промышленности (имеется сертификат TS16949).





100% управление качеством

Компания Yangjie Electronic осуществляет контроль качества на каждом этапе изготовления продукции с помощью собственного высокотехнологического лабораторного оборудования.

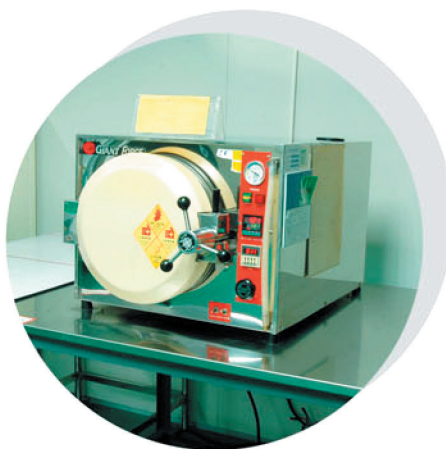

Температурный тест



ISO9001



ISO14001



TS16949



UL



RoHS&Reach



QC080000



RoHS



DIODES & BRIDGE RECTIFIERS SPECIALIST

Продукция компании УЈ

Диодные мосты

Type No.	I _o (A)	V _{RM} (V)	Package
ABS2~ABS10	0.8/1.0	200~1000	ABS
MBL1S~MBL10S	0.8	100~1000	MBLS
MB2S~MB10S	0.5/0.8	200~1000	MBS
MB2M~MB10M	0.5/0.8	200~1000	MBM
DB101~DB107	1	50~1000	DB
DB101S~DB107S	1	50~1000	DBS
DB151~DB157	1.5	50~1000	DB
DB151S~DB157S	1.5	50~1000	DBS
DB201~DB207	2	50~1000	DB
DB201S~DB207S	2	50~1000	DBS
YBS20005~YBS2010	2	50~1000	YBS
YBS22005~YBS2210	2.2	50~1000	YBS
KBP2005~KBP210	2	50~1000	KBP
KBP2005G~KBP210G	2	50~1000	KBP
KBP3005~KBP310	3	50~1000	KBP
KBL4005~KBL410	4	50~1000	KBL
KBL6005~KBL610	6	50~1000	KBL
KBU4005~KBU410	4	50~1000	KBU
KBU6005~KBU610	6	50~1000	KBU
KBU8005~KBU810	8	50~1000	KBU
KBU10005~KBU1010	10	50~1000	KBU
KBU15005~KBU1510	15	50~1000	KBU
KBU25005~KBU2510	25	50~1000	KBU
GBP2005~GBP210	2	50~1000	GBP
GBP2005A~GBP210A	2	50~1000	GBP
D2UB05~D2UB100	2	50~1000	D3K
D2UB05A~D2UB100A	2	50~1000	D3K
GBL2005~GBL210	2	50~1000	GBL
D3UB05~D3UB100	3	50~1000	D3K
D3UB05A~D3UB100A	3	50~1000	D3K
GBP3005~GBP310	3	50~1000	GBP
GBP3005A~GBP310A	3	50~1000	GBP
GBL4005~GBL410	4	50~1000	GBL
D4UB05A~D4UB100A	4	50~1000	D3K
D4UB05~D4UB100	4	50~1000	D3K
GBU4005~GBU410	4	50~1000	GBU
GBU4005A~GBU410A	4	50~1000	GBU
GBP4005~GBP410	4	50~1000	GBP
GBP4005A~GBP410A	4	50~1000	GBP
D6UB05~D6UB100	6	50~1000	D3K
GBU6005~GBU610	6	50~1000	GBU
GBU6005A~GBU610A	6	50~1000	GBU
D8UB05~D8UB100	8	50~1000	D3K
GBU8005~GBU810	8	50~1000	GBU



ABS



MBLS



MBS



MBM



DB



DBS

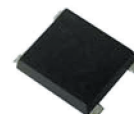

YBS



KBP

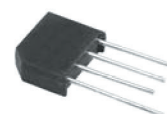

KBL

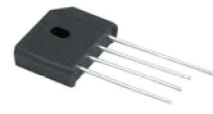

KBU

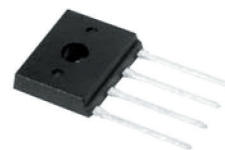

D3K



GBP



GBL

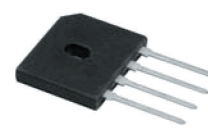

GBU



Type No.	Io(A)	V _{RM} (V)	Package
GBU8005A~GBU810A	8	50~1000	GBU
GBU10005~GBU1010	10	50~1000	GBU
GBU10005A~GBU1010A	10	50~1000	GBU
GBU15005~GBU1510	15	50~1000	GBU
GBU15005A~GBU1510A	15	50~1000	GBU
GBU25005~GBU2510	25	50~1000	GBU
GBJ2005~GBJ210	2	50~1000	KBJ2
KBJ4005~KBJ410	4	50~1000	KBJ4
KBJ6005~KBJ610	6	50~1000	KBJ4
KBJ10005~KBJ1010	10	50~1000	KBJ4
GBJ6005~GBJ610	6	50~1000	KBJ6
GBJ8005~GBJ810	8	50~1000	KBJ6
GBJ10005~GBJ1010	10	50~1000	KBJ6
GBJ15005~GBJ1510	15	50~1000	KBJ6
GBJ20005~GBJ2010	20	50~1000	KBJ6
GBJ25005~GBJ2510	25	50~1000	KBJ6
GBJ35005~GBJ3510	35	50~1000	KBJ6
D4JB05~D4JB100	4	50~1000	JB
D6JB05~D6JB100	6	50~1000	JB
D6JA05~D6JA100	6	50~1000	JA
D8JB05~D8JB100	8	50~1000	JB
D8JA05~D8JA100	8	50~1000	JA
D10JB05~D10JB100	10	50~1000	JB
D10JA05~D10JA100	10	50~1000	JA
D15JA05~D15JA60	15	50~1000	JA
D20JA05~D20JA100	20	50~1000	JA
KBPC1005~KBPC110	3	50~1000	KBPC1
KBPC6005~KBPC610	6	50~1000	KBPC6
KBPC8005~KBPC810	8	50~1000	KBPC8
KBPC10005~KBPC1010	10	50~1000	KBPC8
KBPC15005~KBPC1510	15	50~1000	KBPC25
KBPC25005~KBPC2510	25	50~1000	KBPC25
KBPC35005~KBPC3510	35	50~1000	KBPC25
KBPC5005~KBPC5010	50	50~1000	KBPC25
KBPC1501W~KBPC1510W	15	100~1000	KBPC-W
KBPC25005W~KBPC2510W	25	50~1000	KBPC-W
KBPC35005W~KBPC3510W	35	50~1000	KBPC-W
KBPC50005W~KBPC5010W	50	50~1000	KBPC-W
BR15005~BR1510	15	50~1000	BR
BR25005~BR2510	25	50~1000	BR
BR35005~BR3510	35	50~1000	BR
BR50005~BR5010	50	50~1000	BR
BR15005W~BR1510W	15	50~1000	BR-W



GBU

KBJ2

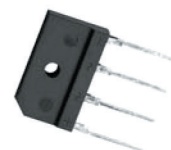

KBJ4



KBJ6

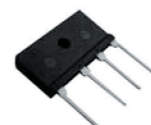

JA



JB



KBPC1



KBPC6



KBPC8

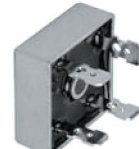

KBPC25

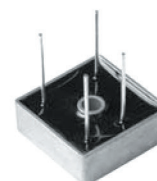

KBPC-W



BR

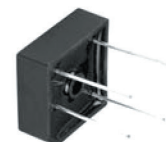

BR-W

Продукция компании УЈ

Диодные мосты

Type No.	Io(A)	V _{RM} (V)	Package
BR25005W~BR2510W	25	50~1000	BR-W
BR35005W~BR3510W	35	50~1000	BR-W
BR50005W~BR5010W	50	50~1000	BR-W
GBPC15005~GBPC1510	15	50~1000	GBPC
GBPC25005~GBPC2510	25	50~1000	GBPC
S25VB10~S25VB100	25	100~1000	S25VB
S35VB10~S35VB100	35	100~1000	S25VB
GBPC35005~GBPC3510	35	50~1000	GBPC
GBPC50005~GBPC5010	50	50~1000	GBPC
GBPC15005W~GBPC1510W	15	50~1000	GBPC-W
GBPC25005W~GBPC2510W	25	50~1000	GBPC-W
GBPC35005W~GBPC3510W	35	50~1000	GBPC-W
GBPC50005W~GBPC5010W	50	50~1000	GBPC-W
BR15005L~BR1510L	15	50~1000	BR-L
BR25005L~BR2510L	25	50~1000	BR-L
BR35005L~BR3510L	35	50~1000	BR-L
BR50005L~BR5010L	50	50~1000	BR-L
SKBPC25005~SKBPC2516	25	50~1600	SKBPC
SKBPC35005~SKBPC3516	35	50~1600	SKBPC
SKBPC50005~SKBPC5016	50	50~1600	SKBPC
DF25NA80~DF25NA160	25	800~1600	TSB-5
DF35NA80~DF35NA160	35	800~1600	TSB-5
MT2504A~MT2516A	25	400~1600	MT
MT3504A~MT3516A	35	400~1600	MT
MT5004A~MT5016A	50	400~1600	MT

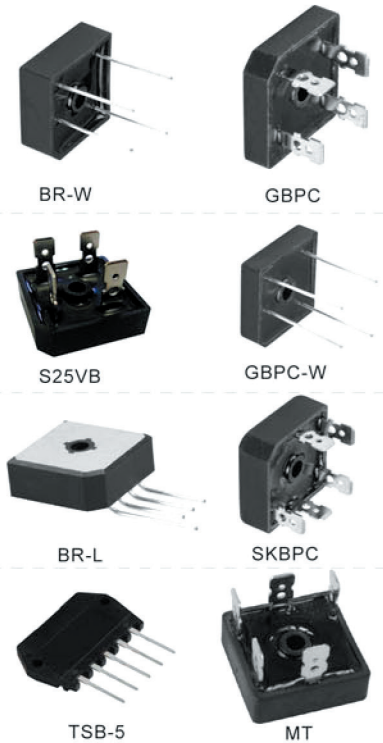

Диоды Shottky

Type No.	Io(A)	V _{RM} (V)	V _F (V)	Package
SR020~SR040	0.5	20~40	0.55	DO-41
SR050~SR060	0.5	50~60	0.7	DO-41
SR090~SR0100	0.5	90~100	0.85	DO-41
1S20~1S40	1	20~40	0.55	R-1
1S50~1S60	1	50~60	0.7	R-1
1S80~1S100	1	80~100	0.8	R-1
1N5817	1	20	0.45	DO-41
1N5818	1	30	0.55	DO-41
1N5819	1	40	0.6	DO-41
SR120~SR140	1	20~40	0.55	DO-41
SR150~SR160	1	50~60	0.7	DO-41
SR180~SR1100	1	80~100	0.8	DO-41
SR220~SR240	2	20~40	0.55	DO-15

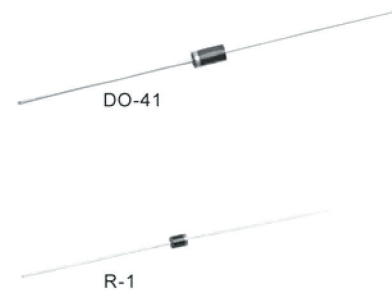



Диоды Shottky

Type No.	Io(A)	V _{RM} (V)	V _F (V)	Package
SR250~SR260	2	50~60	0.7	DO-15
SR280~SR2200	2	80~200	0.85	DO-15
1N5820	3	20	0.475	DO-201AD
1N5821	3	30	0.5	DO-201AD
1N5822	3	40	0.525	DO-201AD
SR320~SR340	3	20~40	0.55	DO-201AD
SR350~SR360	3	50~60	0.7	DO-201AD
SR380~SR3200	3	80~200	0.85	DO-201AD
SR520~SR540	5	20~40	0.55	DO-201AD
SR550~SR560	5	50~60	0.7	DO-201AD
SR580~SR5200	5	80~200	0.85	DO-201AD
SR820~SR840	8	20~40	0.55	DO-201AD
SR850~SR860	8	50~60	0.7	DO-201AD
SR880~SR8200	8	80~200	0.85	DO-201AD
SR540L	5	40	0.4	DO-201AD
SR560L	5	60	0.48	DO-201AD
SR5100L	5	100	0.7	DO-201AD
SR5150L	5	150	0.8	DO-201AD
SR5200L	5	200	0.8	DO-201AD
SR140L	1	40	0.4	DO-41
SR160L	1	60	0.48	DO-41
SR1100L	1	100	0.7	DO-41
SR240L	2	40	0.4	DO-15
SR260L	2	60	0.48	DO-15
SR2100L	2	100	0.7	DO-15
SR340L	3	40	0.4	DO-201AD
SR360L	3	60	0.48	DO-201AD
SR3100L	3	100	0.7	DO-201AD
SR840L	8	40	0.4	DO-201AD
SR860L	8	60	0.48	DO-201AD
SR8150L	8	150	0.8	DO-201AD
SR8200L	8	200	0.8	DO-201AD
SR10100L	10	100	0.7	DO-201AD
SR10150L	10	150	0.8	DO-201AD
SR10200L	10	200	0.8	DO-201AD
SB1240	12	40	0.5	DO-201AD/R-6
MBR820~MBR840	8	20~40	0.6	TO-220AC
MBR850~MBR860	8	50~60	0.75	TO-220AC
MBR880~MBR8100	8	80~100	0.85	TO-220AC
MBR8150~MBR8200	8	150~200	0.9	TO-220AC
MBR1020~MBR1040	10	20~40	0.55	TO-220AC
MBR1050~MBR1060	10	50~60	0.7	TO-220AC
MBR1080~MBR10100	10	80~100	0.88	TO-220AC

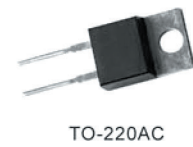
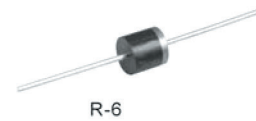

Продукция компании УЈ



Диоды Shottky

Type No.	Io(A)	V _{RM} (V)	V _F (V)	Package
MBR10150~MBR10200	10	150~200	0.9	TO-220AC
MBR1020CT~MBR1045CT	10	20~45	0.65	TO-220AB
MBR1050CT~MBR1060CT	10	50~60	0.75	TO-220AB
MBR1080CT~MBR10100CT	10	80~100	0.8	TO-220AB
MBR10150CT~MBR10200CT	10	150~200	0.9	TO-220AB
MBR1035F~MBR1045F	10	35~45	0.7	ITO-220AC
MBR1050F~MBR1060F	10	50~60	0.8	ITO-220AC
MBR1090F~MBR10100F	10	90~100	0.85	ITO-220AC
MBR10150F~MBR10200F	10	150~200	1.05	ITO-220AC
MBR1035FCT~MBR1040FCT	10	35~40	0.7	ITO-220AB
MBR1050FCT~MBR1060FCT	10	50~60	0.8	ITO-220AB
MBR1090FCT~MBR10100FCT	10	90~100	0.85	ITO-220AB
MBR10150FCT~MBR10200FCT	10	150~200	1.05	ITO-220AB
MBR1530CT~MBR1545CT	15	30~45	0.65	TO-220AB
MBR1550CT~MBR1560CT	15	50~60	0.75	TO-220AB
MBR1590CT~MBR15100CT	15	90~100	0.95	TO-220AB
MBR15150CT~MBR15200CT	15	150~200	1.02	TO-220AB
MBR1535FCT~MBR1545FCT	15	35~45	0.7	ITO-220AB
MBR1550FCT~MBR1560FCT	15	50~60	0.75	ITO-220AB
MBR1590FCT~MBR15100FCT	15	90~100	0.9	ITO-220AB
MBR15150FCT~MBR15200FCT	15	150~200	0.95	ITO-220AB
MBR1635~MBR1645	16	35~45	0.55	TO-220AC
MBR1650	16	50	0.75	TO-220AC
MBR1660	16	60	0.7	TO-220AC
MBR1690~MBR16100	16	90~100	0.9	TO-220AC
MBR16150~MBR16200	16	150~200	1	TO-220AC
MBR1635F~MBR1645F	16	35~45	0.63	ITO-220AC
MBR1650F~MBR1660F	16	50~60	0.75	ITO-220AC
MBR1690F~MBR16100F	16	90~100	0.85	ITO-220AC
MBR16150F~MBR16200F	16	150~200	0.95	ITO-220AC
GF1645LA	16	45	0.55	TO-220AC
GF1645MA	16	45	0.55	TO-263
MBR2035CT~MBR2045CT	20	35~45	0.84	TO-220AB
MBR2050CT~MBR2060CT	20	50~60	0.8	TO-220AB
MBR2090CT~MBR20100CT	20	90~100	0.85	TO-220AB
MBR20150CT	20	150	0.99	TO-220AB
MBR20200CT	20	200	1.02	TO-220AB
MBR2035F~MBR2045F	20	35~45	0.75	ITO-220AC
MBR2050F~MBR2060F	20	50~60	0.85	ITO-220AC
MBR2090F~MBR20100F	20	90~100	0.95	ITO-220AC
MBR20150F~MBR20200F	20	150~200	1.02	ITO-220AC



TO-220AC

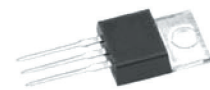

TO-220AB



ITO-220AC



ITO-220AB



ITO-220AC



TO-263



Диоды Shottky

Type No.	Io(A)	VRM(V)	VF(V)	Package
MBR2035FCT~MBR2045FCT	20	35~45	0.75	ITO-220AB
MBR2050FCT~MBR2060FCT	20	50~60	0.85	ITO-220AB
MBR2090FCT~MBR20100FCT	20	90~100	0.95	ITO-220AB
MBR20150FCT~MBR20200FCT	20	150~200	1.02	ITO-220AB
MBR2035PT~MBR2045PT	20	35~45	0.84	TO-3P/TO-247AD
MBR2050PT~MBR2060PT	20	50~60	0.8	TO-3P/TO-247AD
MBR2090PT~MBR20100PT	20	90~100	0.85	TO-3P/TO-247AD
MBR20150PT	20	150	0.95	TO-3P/TO-247AD
MBR20200PT	20	200	1.02	TO-3P/TO-247AD
MBR2535FCT~MBR2545FCT	25	35~45	0.75	ITO-220AB
MBR2550FCT~MBR2560FCT	25	50~60	0.85	ITO-220AB
MBR2590FCT	25	90	0.95	ITO-220AB
MBR25100FCT	25	100	0.95	ITO-220AB
MBR25150FCT~MBR25200FCT	25	150~200	1.02	ITO-220AB
GF2545LC	25	45	0.55	TO-220AC
GF2545MC	25	45	0.55	TO-263
MBR25100CT	25	100	0.85	TO-220AB
MBR25150CT~MBR25200CT	25	150~200	0.95	TO-220AB
MBR2535FCT~MBR2545FCT	25	35~45	0.75	ITO-220AB
MBR2550FCT~MBR2560FCT	25	50~60	0.85	ITO-220AB
MBR2590FCT~MBR25100FCT	25	90~100	0.95	ITO-220AB
MBR25150FCT~MBR25200FCT	25	150~200	1.02	ITO-220AB
MBR3035CT~MBR3045CT	30	35~45	0.7	TO-220AB
MBR3050CT~MBR3060CT	30	50~60	0.8	TO-220AB
MBR3080CT~MBR30100CT	30	80~100	0.95	TO-220AB
MBR30150CT~MBR30200CT	30	150~200	1.02	TO-220AB
MBR3030FCT~MBR3045FCT	30	35~45	0.7	ITO-220AB
MBR3050FCT~MBR3060FCT	30	50~60	0.75	ITO-220AB
MBR3090FCT~MBR30100FCT	30	90~100	0.85	ITO-220AB
MBR30150FCT~MBR30200FCT	30	150~200	0.95	ITO-220AB
MBR3035PT~MBR3045PT	30	35~45	0.82	TO-3P/TO-247AD
MBR3050PT~MBR3060PT	30	50~60	0.75	TO-3P/TO-247AD
MBR3090PT~MBR30100PT	30	90~100	0.85	TO-3P/TO-247AD
MBR30150PT~MBR30200PT	30	150~200	0.95	TO-3P/TO-247AD
MBR4035PT~MBR4045PT	40	35~45	0.75	TO-3P/TO-247AD
MBR4050PT~MBR4060PT	40	50~60	0.77	TO-3P/TO-247AD
MBR4090PT~MBR40100PT	40	90~100	0.84	TO-3P/TO-247AD
MBR40150PT~MBR40200PT	40	150~200	0.95	TO-3P/TO-247AD

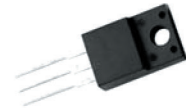

ITO-220AB



TO-3P-247AD



TO-220AC



TO-263

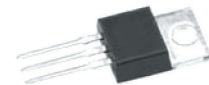

TO-220AB



ITO-220AB

Продукция компании YJ



Диоды Shottky

Type No.	Io(A)	VRM(V)	VF(V)	Package
LL5817	1	20	0.45	MELF
LL5818	1	30	0.55	MELF
LL5819	1	40	0.6	MELF
LSR120~LSR140	1	20~40	0.55	MELF
LSR150~LSR160	1	50~60	0.7	MELF
S12L~S14L	1	20~40	0.5	SOD-123HE
S15L~S16L	1	50~60	0.7	SOD-123HE
S18L~S110L	1	80~100	0.85	SOD-123HE
S115L~S120L	1	150~200	0.9	SOD-123HE
S12~S14	1	20~40	0.5	SOD-123FL
S15~S16	1	50~60	0.7	SOD-123FL
S18~S110	1	80~100	0.85	SOD-123FL
S115~S120	1	150~200	0.9	SOD-123FL
SS12~SS14	1	20~40	0.5	SMA-W
SS15~SS16	1	50~60	0.75	SMA-W
SS12A~SS14A	1	20~40	0.5	SMA
SS15A~SS16A	1	50~60	0.7	SMA
SS18A~SS110A	1	80~100	0.85	SMA
SS115A~SS120A	1	150~200	0.9	SMA
S22L~S24L	2	20~40	0.5	SOD-123HE
S25L~S26L	2	50~60	0.7	SOD-123HE
S28L~S210L	2	80~100	0.85	SOD-123HE
S215L~S220L	2	150~200	0.9	SOD-123HE
S22~S24	2	20~40	0.5	SOD-123FL
S25~S26	2	50~60	0.7	SOD-123FL
S28~S210	2	80~100	0.85	SOD-123FL
S215~S220	2	150~200	0.9	SOD-123FL
SS22A~SS24A	2	20~40	0.5	SMA
SS25A~SS26A	2	50~60	0.7	SMA
SS28A~SS210A	2	80~100	0.85	SMA
SS215A~SS220A	2	150~200	0.9	SMA
S22F~S24F	2	20~40	0.5	SMAF
S25F~S26F	2	50~60	0.7	SMAF
S28F~S210F	2	80~100	0.85	SMAF
S215F~S220F	2	150~200	0.9	SMAF
SS22~SS24	2	20~40	0.5	SMB
SS25~SS26	2	50~60	0.7	SMB
SS28~SS210	2	80~100	0.85	SMB
SS215~SS220	2	150~200	0.9	SMB
S32L~S34L	2	20~40	0.5	SOD-123HE
S35L~S36L	2	50~60	0.7	SOD-123HE
S38L~S310L	2	80~100	0.85	SOD-123HE
S315L~S320L	3	150~200	0.9	SOD-123HE
S32~S34	3	20~40	0.5	SOD-123FL
S35~S36	3	50~60	0.7	SOD-123FL
S38~S310	3	80~100	0.85	SOD-123FL



MELF



SOD-123HE



SMA-W



SOD-123FL



SMA



SMAF



SMB



Диоды Shottky

Type No.	Io(A)	VRM(V)	VF(V)	Package
S315~S320	3	150~200	0.9	SOD-123FL
S32F~S34F	3	20~40	0.5	SMAF
S35F~S36F	3	50~60	0.7	SMAF
S38F~S310F	3	80~100	0.85	SMAF
S315F~S320F	3	150~200	0.9	SMAF
SS32~SS34	3	20~40	0.5	SMC
SS35~SS36	3	50~60	0.7	SMC
SS38~SS310	3	80~100	0.85	SMC
SS315~SS320	3	150~200	0.9	SMC
SS32A~SS34A	3	20~40	0.5	SMA
SS35A~SS36A	3	50~60	0.7	SMA
SS38A~SS310A	3	80~100	0.85	SMA
SS315A~SS320A	3	150~200	0.9	SMA
SS32B~SS34B	3	20~40	0.5	SMB
SS35B~SS36B	3	50~60	0.7	SMB
SS38B~SS310B	3	80~100	0.85	SMB
SS315B~SS320B	3	150~200	0.9	SMB
SS52B~SS53B	5	20~30	0.55	SMB
SS54B	5	40	0.6	SMB
SS55B~SS56B	5	50~60	0.7	SMB
SS58B~SS510B	5	80~100	0.85	SMB
SS515B~SS520B	5	150~200	0.9	SMB
SS52~SS53	5	20~30	0.55	SMC
SS54	5	40	0.6	SMC
SS55~SS56	5	50~60	0.7	SMC
SS58~SS510	5	80~100	0.85	SMC
SS515~SS520	5	150~200	0.9	SMC
SS5U45	5	45	0.5	TO-277
SS10U45	10	45	0.47	TO-277
SS15U45	15	45	0.46	TO-277



SOD-123FL



SMAF



SMC



SMA



SMB



TO-277



Диоды PV

Type No.	Io(A)	VRM(V)	VF(V)	Package
10SQ030~10SQ035	10	30~35	0.55	R-6
10SQ040~10SQ060	10	40~60	0.7	R-6
10SQ080~10SQ100	10	80~100	0.8	R-6
12SQ040~12SQ045	12	40~45	0.55	R-6
15SQ045	15	45	0.5	R-6
20SQ040~20SQ045	20	40~45	0.55	R-6
20SQ040	20	40	0.55	R-7
GF1640LAF	16	40	0.5	ITO-220AC
GF1640MC	16	40	0.5	TO-263
GF1645LA	16	45	0.5	TO-263
GF1645MA	16	45	0.5	TO-220AB
GF2045MG	20	45	0.55	TO-263
GF2045LA	20	45	0.55	TO-220AC
GF2045LG	20	45	0.55	TO-220AC



R-6

R-7



ITO-220AC



TO-263

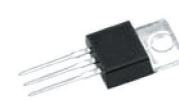

TO-220AB



TO-220AC

Продукция компании YJ

Диоды PV

Type No.	Io(A)	V _{RM} (V)	V _F (V)	Package
GF2545MG	25	45	0.55	TO-263
GF2545MC	25	45	0.55	TO-263
GF2545LC	25	45	0.55	TO-220AC
GF3045LA	30	45	0.55	TO-220AC
GF3045MG	30	45	0.55	TO-263
GFS1845A	18	45	0.45	GF004
GFS1845B	18	45	0.52	GF004
GFS2045	20	45	0.5	GF004
GFMK2545	25	45	0.58	GF009
GFMK3045	30	45	0.55	GF009



Супербыстрые диоды

Type No.	Io(A)	V _{RM} (V)	T _{RR} (ns)	Package
1S1~1S8	1	50~600	35	R-1
1S1G~1S8G	1	50~600	35	R-1
SF11S~SF18S	1	50~600	35	A-405
SF11GS~SF18GS	1	50~600	35	A-405
SF11~SF18	1	50~600	35	DO-41
SF11G~SF18G	1	50~600	35	DO-41
SF21~SF28	2	50~600	35	DO-15
SF21G~SF28G	2	50~600	35	DO-15
SF31~SF38	3	50~600	35	DO-201AD
SF31G~SF38G	3	50~600	35	DO-201AD
MUR460	4	600	50	DO-201AD
MUR560	5	600	50	DO-201AD
SF51~SF58	5	50~600	35	DO-201AD
SF51G~SF58G	5	50~600	35	DO-201AD
SF61~SF68	6	50~600	35	DO-201AD
SF61G~SF68G	6	50~600	35	R-6
E1AL~E1JL	1	50~600	35	SOD-123HE
E1A~E1J	1	50~600	35	SOD-123FL
E1AF~E1JF	1	50~600	35	SMAF
E2AF~E2JF	2	50~600	35	SMAF
MUR510~MUR520	5	50~200	35	TO-200AC
MUR540~MUR560	5	400~600	50	TO-200AC
MUR510F~MUR520F	5	50~200	35	ITO-200AC
MUR540F~MUR560F	5	400~600	50	ITO-200AC
MUR810~MUR820	8	100~200	35	TO-220AC
MUR840~MUR860	8	400~600	50	TO-221AC
MUR810F~MUR820F	8	100~200	35	ITO-220AC
MUR840F~MUR860F	8	400~600	50	ITO-220AC
MUR1010~MUR1020	10	100~200	35	TO-220AC
MUR1040~MUR1060	10	400~600	50	TO-220AC

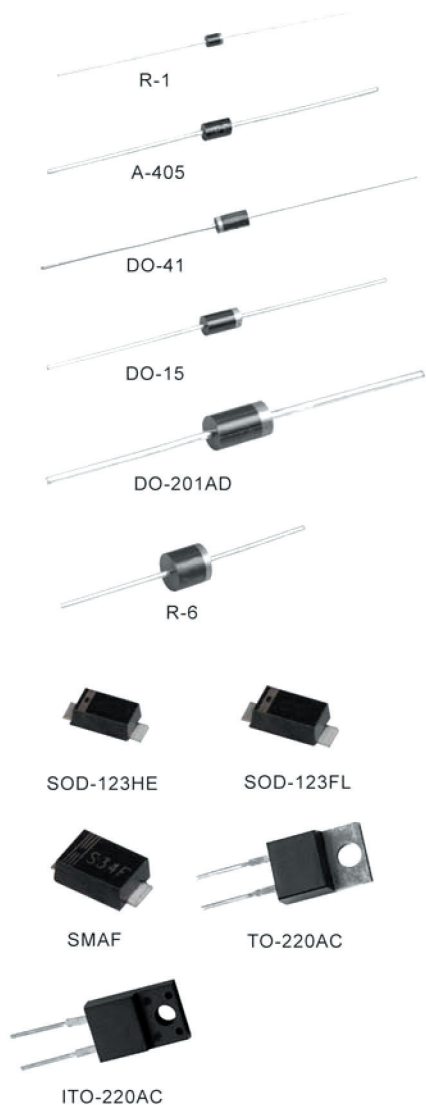



Супербыстрые диоды

Type No.	Io(A)	V _{RM} (V)	T _{RR} (ns)	Package
MUR1010F~MUR1020F	10	100~200	35	ITO-200AC
MUR1040F~MUR1060F	10	400~600	50	ITO-200AC
MUR1010CT~MUR1020CT	10	100~200	35	TO-220AB
MUR1040CT~MUR1060CT	10	400~600	50	TO-220AB
MUR1010FCT~MUR1020FCT	10	50~200	35	ITO-220AB
MUR1040FCT~MUR1060FCT	10	400~600	50	ITO-220AB
MUR1610~MUR1620	16	100~200	35	TO-220AB
MUR1640~MUR1660	16	400~600	50	TO-220AB
MUR1610F~MUR1620F	16	100~200	35	ITO-200AC
MUR1640F~MUR1660F	16	400~600	50	ITO-200AC
MUR1610CT~MUR1620CT	16	100~200	35	TO-220AB
MUR1640CT~MUR1660CT	16	400~600	50	TO-220AB
MUR1610FCT~MUR1620FCT	16	100~200	35	ITO-220AB
MUR1640FCT~MUR1660FCT	16	400~600	50	ITO-220AB
MUR2010~MUR2020	20	100~200	35	TO-220AB
MUR2040~MUR2060	20	400~600	50	TO-220AB
MUR2010F~MUR2020F	20	100~200	35	ITO-200AC
MUR2040F~MUR2060F	20	400~600	50	ITO-200AC
MUR2010CT~MUR2020CT	20	100~200	35	TO-220AB
MUR2040CT~MUR2060CT	20	400~600	50	TO-220AB
MUR2010FCT~MUR2020FCT	20	100~200	35	ITO-220AB
MUR2040FCT~MUR2060FCT	20	400~600	50	ITO-220AB
ES1AW~ES1JW	1	50~600	35	SMA-W
ES1A~ES1J	1	50~600	35	SMA
ES2AA~ES2JA	2	50~600	35	SMA
ES2A~ES2J	2	50~600	35	SMB
ES3AB~ES3JB	3	50~600	35	SMB
ES3A~ES3J	3	50~600	35	SMC
ES5A~ES5J	5	50~600	35	SMC



ITO-220AC



TO-220AB

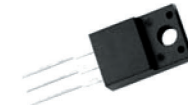

ITO-220AB



SMA-W



SMA



SMB



SMC



Диоды общего назначения

Type No.	Io(A)	V _{RM} (V)	Package
1A1~1A7	1	50~1000	R-1
1A1G~1A7G	1	50~1000	R-1
1N4001S~1N4007S	1	50~1000	A-405
1N4001GS~1N4007GS	1	50~1000	A-405



R-1



A-405

Продукция компании YJ



Диоды общего назначения

Type No.	Io(A)	VRM(V)	Package
1N4001~1N4007	1	50~1000	DO-41
1N4001G~1N4007G	1	50~1000	DO-41
1N5391S~1N5399S	1.5	50~1000	DO-41
1N5391G~1N5399G	1.5	50~1000	DO-15
1N5391~1N5399	1.5	50~1000	DO-15
RL201~RL207	2	50~1000	DO-15
RL201G~RL207G	2	50~1000	DO-15
RL251~RL257	2.5	50~1000	DO-15
RL251G~RL257G	2.5	50~1000	DO-15
1N5400~1N5408	3	50~1000	DO-201AD
1N5400G~1N5408G	3	50~1000	DO-201AD
BY251~BY255	3	200~1300	DO-201AD
BY251G~BY255G	3	200~1300	DO-201AD
P6A05~P6A10	6	50~1000	R-6
P6A05G~P6A10G	6	50~1000	R-6
10A05~10A10	10	50~1000	R-6
10A05G~10A10G	10	50~1000	R-6
LL4001~LL4007	1	50~1000	MELF
G1AL~G1ML	1	50~1000	SOD-123HE
G07A~G07M	0.7	50~1000	SOD-123FL
G1A~G1M	1	50~1000	SOD-123FL
G15AL~G15ML	1.5	50~1000	SOD-123HE
G15A~G15M	1.5	50~1000	SOD-123FL
G1AF~G1MF	1	50~1000	SMAF
G2AF~G2MF	2	50~1000	SMAF
M1~M7	1	50~1000	SMA-W
M1G~M7G	1	50~1000	SMA-W
GS1A~GS1M	1	50~1000	SMA
GS2AA~GS2MA	2	50~1000	SMA
GS2A~GS2M	2	50~1000	SMB
GS3AB~GS3MB	3	50~1000	SMB
GS3A~GS3M	3	50~1000	SMC
GS5A~GS5M	5	50~1000	SMC

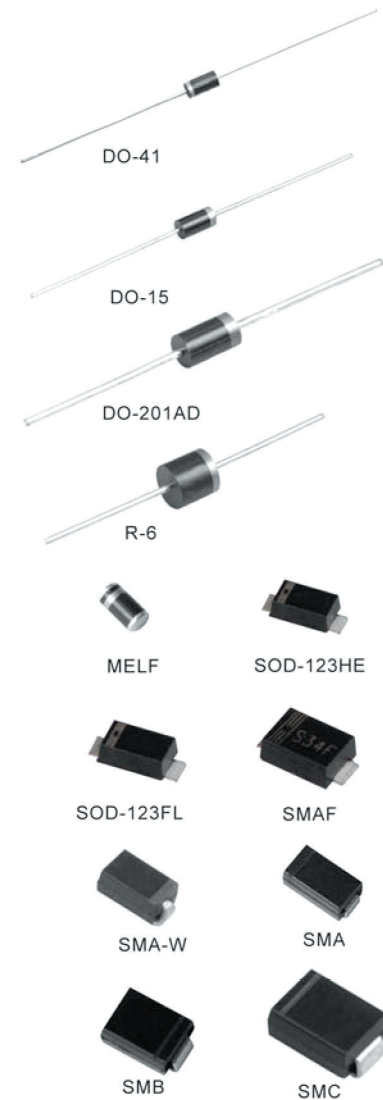

Высокоэффективные диоды

Type No.	Io(A)	VRM(V)	TRR(ns)	Package
1H1~1H5	1	50~400	50	R-1
1H6~1H8	1	600~1000	75	R-1
1H1G~1H5G	1	50~400	50	R-1
1H6G~1H8G	1	600~1000	75	R-1
HER101S~HER105S	1	50~400	50	A-405
HER106S~HER108S	1	600~1000	75	A-405

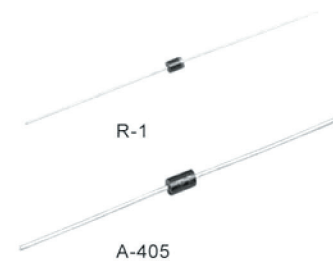



Высокоэффективные диоды

Type No.	Io(A)	VRM(V)	TRR(ns)	Package
HER101GS~HER105GS	1	50~400	50	A-405
HER106GS~HER108GS	1	600~1000	75	A-405
HER101~HER105	1	50~400	50	DO-41
HER106~HER108	1	600~1000	75	DO-41
HER101G~HER105G	1	50~400	50	DO-41
HER106G~HER108G	1	600~800	75	DO-41
UF4001~UF4004	1	50~400	50	DO-41
UF4005~UF4007	1	600~1000	75	DO-41
HER151~HER155	1.5	50~400	50	DO-15
HER156~HER158	1.5	600~1000	75	DO-15
HER151G~HER155G	1.5	50~400	50	DO-15
HER156G~HER158G	1.5	600~1000	75	DO-15
HER201~HER205	2	50~400	50	DO-15
HER206~HER208	2	600~1000	75	DO-15
HER201G~HER205G	2	50~400	50	DO-15
HER206G~HER208G	2	600~1000	75	DO-15
UF2001~UF2004	2	50~400	50	DO-15
UF2005~UF2007	2	600~1000	75	DO-15
HER301~HER305	3	50~400	50	DO-201AD
HER306~HER308	3	600~1000	75	DO-201AD
HER301G~HER305G	3	50~400	50	DO-201AD
HER306G~HER308G	3	600~1000	75	DO-201AD
UF5400~UF5404	3	50~400	50	DO-201AD
UF5406~UF5408	3	600~1000	75	DO-201AD
HER601~HER605	6	50~400	50	R-6
HER606~HER608	6	600~1000	75	R-6
HER601G~HER605G	6	50~400	50	R-6
HER606G~HER608G	6	600~1000	75	R-6
US1A~US1G	1	50~400	50	SMA-W
US1J~US1M	1	600~1000	75	SMA-W
H1AL~H1GL	1	50~400	50	SOD-123HE
H1JL~H1ML	1	600~1000	75	SOD-123HE
H1A~H1G	1	50~400	50	SOD-123FL
H1J~H1M	1	600~1000	75	SOD-123FL
H1AF~H1GF	1	50~400	50	SMAF
H1JF~H1MF	1	600~1000	75	SMAF
H2AF~H2GF	2	50~400	50	SMAF
H2JF~H2MF	2	600~1000	75	SMAF
HS1A~HS1G	1	50~400	50	SMA
HS1J~HS1M	1	600~1000	75	SMA
HS2AA~HS2GA	2	50~400	50	SMA
HS2JA~HS2MA	2	600~1000	75	SMA
HS2A~HS2G	2	50~400	50	SMB
HS2J~HS2M	2	600~1000	75	SMB
HS3AB~HS3GB	3	50~400	50	SMB
HS3JB~HS3MB	3	600~1000	75	SMB
HS3A~HS3G	3	50~400	50	SMC
HS3J~HS3M	3	600~1000	75	SMC
HS5A~HS5G	5	50~400	50	SMC
HS5J~HS5M	5	600~1000	75	SMC

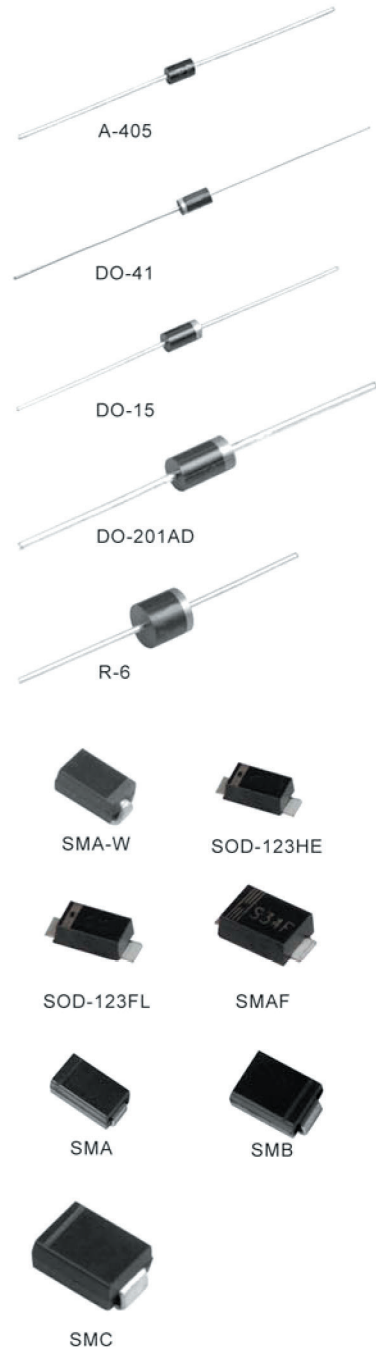

Продукция компании YJ

Быстровосстанавливающиеся диоды

Type No.	Io(A)	V _{RM} (V)	T _{RR} (ns)	Package
1F1~1F4	1	50~400	150	R-1
1F5	1	600	250	R-1
1F6~1F7	1	800~1000	500	R-1
1F1G~1F4G	1	50~400	150	R-1
1F5G	1	600	250	R-1
1F6G~1F7G	1	800~1000	500	R-1
FR101S~FR104S	1	50~400	150	A-405
FR105S	1	600	250	A-405
FR106S~FR107S	1	800~1000	500	A-405
FR101GS~FR104GS	1	50~400	150	A-405
FR105GS	1	600	250	A-405
FR106GS~FR107GS	1	800~1000	500	A-405
BA157	1	400	150	DO-41
BA158	1	600	250	DO-41
BA159	1	1000	500	DO-41
1N4933~1N4937	1	50~600	150	DO-41
1N4933G~1N4937G	1	50~600	150	DO-41
FR101~FR104	1	50~400	150	DO-41
FR105	1	600	250	DO-41
FR106~FR107	1	800~1000	500	DO-41
FR101G~FR104G	1	50~400	150	DO-41
FR105G	1	600	250	DO-41
FR106G~FR107G	1	800~1000	500	DO-41
FR151S~FR154S	1.5	50~400	150	DO-41
FR155S	1.5	600	250	DO-41
FR156S~FR157S	1.5	800~1000	500	DO-41
FR151GS~FR154GS	1.5	50~400	150	DO-41
FR155GS	1.5	600	250	DO-41
FR156GS~FR157GS	1.5	800~1000	500	DO-41
FR151~FR154	1.5	50~400	150	DO-15
FR155	1.5	600	250	DO-15
FR156~FR157	1.5	800~1000	500	DO-15
FR151G~FR154G	1.5	50~400	150	DO-15
FR155G	1.5	600	250	DO-15
FR156G~FR157G	1.5	800~1000	500	DO-15
FR201~FR204	2	50~400	150	DO-15
FR205	2	600	250	DO-15
FR206~FR207	2	800~1000	500	DO-15
FR201G~FR204G	2	50~400	150	DO-15
FR205G	2	600	250	DO-15
FR206G~FR207G	2	800~1000	500	DO-15
FR301~FR304	3	50~400	150	DO-201AD
FR305	3	600	250	DO-201AD
FR306~FR307	3	800~1000	500	DO-201AD
FR301G~FR304G	3	50~400	150	DO-201AD
FR305G	3	600	250	DO-201AD
FR306G~FR307G	3	800~1000	500	DO-201AD
BY296~BY299	2	100~800	250	DO-201AD
BY396~BY399	3	100~800	250	DO-201AD
FR601~FR604	6	50~400	150	R-6
FR605	6	600	250	R-6
FR606~FR607	6	800~1000	500	R-6
FR601G~FR604G	6	50~400	150	R-6
FR605G	6	600	250	R-6
FR606G~FR607G	6	800~1000	500	R-6

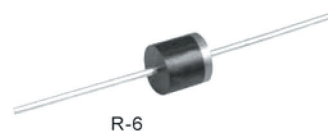

Type No.	Io(A)	V _{RM} (V)	T _{RR} (ns)	Package
F1AL~F1GL	1	50~400	150	SOD-123HE
F1JL	1	600	250	SOD-123HE
F1KL~F1ML	1	800~1000	500	SOD-123HE
F1A~F1G	1	50~400	150	SOD-123FL
F1J	1	600	250	SOD-123FL
F1K~F1M	1	800~1000	500	SOD-123FL
F1AF~F1GF	1	50~400	150	SMAF
F1JF	1	600	250	SMAF
F1KF~F1MF	1	800~1000	500	SMAF
F2AF~F2GF	2	50~400	150	SMAF
F2JF	2	600	250	SMAF
F2KF~F2MF	2	800~1000	500	SMAF
RS1A~RS1G	1	50~400	150	SMA-W
RS1J	1	600	250	SMA-W
RS1K~RS1M	1	800~1000	500	SMA-W
GR1A~GR1G	1	50~400	150	SMA
GR1J	1	600	250	SMA
GR1K~GR1M	1	800~1000	500	SMA
GR2AA~GR2GA	2	50~400	150	SMA
GR2JA	2	600	250	SMA
GR2KA~GR2MA	2	800~1000	500	SMA
GR2A~GR2G	2	50~400	150	SMB
GR2J	2	600	250	SMB
GR2K~GR2M	2	800~1000	500	SMB
GR3AB~GR3GB	3	50~400	150	SMC
GR3JB	3	600	250	SMC
GR3KB~GR3MB	3	800~1000	500	SMC
GR3A~GR3G	3	50~400	150	SMC
GR3J	3	600	250	SMC
GR3K~GR3M	3	800~1000	500	SMC
GR5A~GR5G	5	50~400	150	SMC
GR5J	5	600	250	SMC
GR5K~GR5M	5	800~1000	500	SMC



SOD-123HE



SOD-123FL



SMAF



SMA-W



SMA



SMB



SMC



Защитные диоды

Type No.	V _{RM} (V)	PD(W)	Package
SMF5.0A~SMF58A	6.4~64.4	200	SOD-123FL
SMF60A~SMF170A	66.7~189	175	SOD-123FL
P4KE6.8/C~P4KE500/C	6.8~600	400	DO-41
P4KE6.8A/CA~P4KE500A/CA	6.8~600	400	DO-41
P6KE6.8/C~P6KE600/C	6.8~600	600	DO-15
P6KE6.8A/CA~P6KE600A/CA	6.8~600	600	DO-15
1.5KE6.8/C~1.5KE600/C	6.12~540	1500	DO-201AD
1.5KE6.8A/CA~1.5KE600A/CA	6.45~570	1500	DO-201AD
SA5.0/C~SA190/C	6.4~600	500	DO-15
SA5.0A/CA~SA190A/CA	6.4~600	500	DO-15
3KP5.0/C~3KP190/C	6.4~190	3000	R-6
3KP5.0A/CA~3KP190A/CA	6.4~190	3000	R-6
SMAJ5.0(C)~SMAJ190(C)	6.4~211	400	SMA
SMAJ5.0A/CA~SMAJ440A/CA	6.4~492	400	SMA



SOD-123FL



DO-41



DO-201AD



DO-15



R-6



SMA

Продукция компании YJ



Защитные диоды

Type No.	V _{RM} (V)	PD(W)	Package
P4SMA6.8A/CA~P4SMA600A/CA	6.46~570	400	SMA
SMBJ5.0(C)~SMBJ190(C)	6.4~211.3	600	SMB
SMBJ5.0A/CA~SMBJ440A/CA	6.4~492	600	SMB
P6SMB6.8A/CA~P6SMB600A/CA	6.46~570	600	SMB
SMCJ5.0A/CA~SMCJ440A/CA	6.4~492	1500	SMC
SMCJ5.0(C)~SMCJ190(C)	6.4~211.3	1500	SMC
1.5SMC6.8A/CA~1.5SMC600A/CA	6.46~570	1500	SMC
SMPJ5.0A/CA~SMPJ440A/CA	6.4~492	1500	TO-277
1.5SMP6.8A/CA~1.5SMP600A/CA	6.46~570	1500	TO-277
SMDJ5.0A/CA~SMDJ440A/CA	6.4~492	3000	SMC
SMDJ5.0(C)~SMDJ190(C)	6.4~211.3	3000	SMC
5.0SMDJ11(C)~5.0SMDJ190(C)	12.2~211.3	5000	SMC
5.0SMDJ11A/CA~5.0SMDJ440A/CA	12.2~492	5000	SMC



SMA



SMB



SMC



Стабилитроны

Type No.	V _Z (V)	PD(W)	Package
BZX55C2V4~BZX55C200	2.28~212	0.5	DO-35
BZX55B2V7~BZX55B200	2.35~204	0.5	DO-35
1N5221~1N5262	2.4~51	0.5	DO-35
1N4728~1N4764	3.3~100	1	DO-41
1N5220B~1N5956B	6.2~200	1.5	DO-41
1N4728A~1N4764A	3.3~100	1	DO-41G
2EZ6.2D5~2EZ330D5	6.2~330	2	DO-15
3EZ6.2D5~3EZ200D5	6.2~200	3	DO-15
1N5333B~1N5388B	3.3~200	5	DO-201AE
ZMM55C2V4~ZMM55C75V	2.28~80	0.5	LL-34
ZMM55B2V4~ZMM55B75V	2.35~76.5	0.5	LL-34
ZMM5221~ZMM5262	2.4~51	0.5	LL-34
SMA4728A~SMA4764A	3.3~100	1	SMA
SMA5920B~SMA5956B	6.2~200	1.5	SMA
SMF4728~SMF4764	3.3~100	1	SOD-123FL
SMF5920~SMF5956	6.2~200	1.5	SOD-123FL
SMB2EZ6.2~SMB2EZ330	6.2~330	2	SMB
SMB3EZ6.2~SMB3EZ200	6.2~200	3	SMB
SMC5341B~SMC5388B	6.2~200	5	SMC
DL4728A~DL4764A	3.3~100	1	DL-41
BZV55B2V4~BZV55B75	2.4~75	0.5	MELF
BZV55C2V4~BZV55C75	2.4~75	0.5	MELF
BZM55C2V4~BZM55C75	2.4~75	0.5	MELF
BZX84C2V4~BZX84C39	2.4~39	0.3	SOT23
BZX85C2V7~BZX85C200	2.7~200	1.3	DO-41
BZV85C2V7~BZV85C75	2.7~75	1.3	DO-41



DO-35



DO-41



DO-15



DO-201AE



LL-34



SMA



SOD-123FL



SMB



DL-41



MELF



Динисторы

Type No.	Maximun Peak Pulse(A)	Breakover Voltage(V)	Package
DB3	2	28~36	DO-35
DB4	2	35~45	DO-35



DO-35



Маломощные диоды

Type No.	Ifms(mA)	V _{RM} (V)	Package
1N60	150	40	DO-35
1N60P	400	40	DO-35
LL60	150	40	LL-34
LL60P	400	40	LL-34
BAT45	60	15	DO-35
BAT85	600	30	DO-35



DO-35



LL-34



Маломощные переключающиеся диоды

Type No.	IF(AV)	V _{RM} (V)	Package
1N4148	150	100	DO-35
LL4148	150	100	LL-34



DO-35

Type No.	I _{RM} (μ A)	V _R (V)	Package
1SS181~1SS187	0.5	80	SOT-23
MMBD4148	2.5	75	SOT-23
BAV70~BAV99	2.5	70	SOT-23
BAV199	0.005	70	SOT-23
BAS21	1	200	SOT-23
1N4148W	2.5	75	SOD-123FL
1N4448W	5	75	SOD-123FL
1N914BW	5	75	SOD-123FL
BAV19W~BAV21W	0.1	120~250	SOD-123FL
1N4148WS	5	75	SOD-323
1N4448WS	5	75	SOD-323
1N914BWS	5	75	SOD-323
1SS355	0.1	80	SOD-323
BAS21M3	0.15	250	SOD-323
BAV19WS~BAV21WS	0.1	120~250	SOD-323
1N4148WT	5	75	SOD-523
1N4448WT	5	75	SOD-523
1N914WT	5	75	SOD-523
1SS400	0.1	80	SOD-523
BAS16	1	75	SOD-523
1N4148M9	5	75	SOD-923
BAS16M9	1	75	SOD-923
BAW56	2.5	70	SOT-23
MMBD7000	1	50	SOT-23

LL-34



SOT-23



SOD-123FL



SOD-323



SOD-523



SOD-923

Продукция компании УЈ



Маломощные стабилитроны

Type No.	Pd(mW)	Nom(V)	Package
MMSZ2V4BW ~MMSZ75VBW	500	2.4~75	SOD-123
MMSZ2V0CW~MMSZ75VCW	500	2.0~75	SOD-123
MMSZ5221BW ~MMSZ5267BW	500	2.4~75	SOD-123
MMSZ5230CW~MMSZ5267CW	500	4.3~75	SOD-123
MM3Z2V4BW~MM3Z36VBW	200	2.53~36	SOD-323
MM3Z2V4CW~MM3Z75VCW	200	2.4~75	SOD-323
MMSZ5221BSW~MMSZ5267BSW	200	2.4~75	SOD-323
MMSZ5229CSW ~MMSZ5267CSW	200	4.3~75	SOD-323
MM5Z2V4 ~MM5Z75V	200	2.4~75	SOD-523
MM5Z2V4B~MM5Z75VB	200	2.4~75	SOD-523
BZX584B2V4 ~BZX584B75V	200	2.4~75	SOD-523
BZX584C2V4~BZX584C75V	200	2.4~75	SOD-523



SOD-123



SOD-323



SOD-523



Маломощные диоды Schottky

Type No.	If(A)	VRRM(V)	Package
BAT54/A/C/S	0.2	30.0	SOT-23
BAT42W~BAT54W	0.2	30.0	SOD-123
SD103AW/BW/CW	0.35	20~40	SOD-123
B5819W	1.0	40.0	SOD-123
RB551M3-30	0.5	30.0	SOD-323
RB500M3-40~RB501M3-40	0.1	45.0	SOD-323
BAT42M3~BAT54M3	0.2	30.0	SOD-323
RB751M3-40	0.03	40.0	SOD-323
PSB3002M3	0.2	30.0	SOD-323
SD103AM3	0.35	40.0	SOD-323
BAS70M3	0.07	70.0	SOD-323
RB520GM3-30	0.1	30.0	SOD-323
RB520ZM3-30	0.1	30.0	SOD-323
RB521M3-30	0.1	30.0	SOD-323
RB520S-30~RB521S-30	0.2	30.0	SOD-523
RB520S-40	0.2	40.0	SOD-523
RB751S-40	0.03	40.0	SOD-523
BAT42XV2~BAT54XV2	0.2	30.0	SOD-523
RB751M9-40	0.03	40.0	SOD-923
RB520GM9-30	0.1	30.0	SOD-923
RB521M9-30	0.1	30.0	SOD-923
BAT42M9~BAT54M9	0.2	30.0	SOD-923
BAS70M9	0.07	70.0	SOD-923
RB520ZM9-30	0.1	30.0	SOD-923
BAT720	0.50	40.0	SOT-23



SOT-23



SOD-123



SOD-323



SOD-523



SOD-923



Маломощные TVS диоды

Type No.	P _D (mW)	V _{RWM} (V)	Package
ESD5.0XM3	150	5.0	SOD323
ESD3.3XM3	150	3.3	SOD323
ESD5.0LM3	150	5.0	SOD323
ESD5.0ZM3	200	5.0	SOD323
ESD05M3	200	5.0	SOD323
ESD12M3	150	12.0	SOD323
ESD5.0XM9	150	5.0	SOD923
ESD3.3XM9	150	3.3	SOD923
ESD5.0ZM9	200	5.0	SOD923
ESD5.0LM9	150	5.0	SOD923
ESD5.0LAM9	150	5.0	SOD923
ESD6.0ZM9	200	6.0	SOD923
ESD7.0ZM9	200	7.0	SOD923
ESDB3.3EM9	150	3.3	SOD923
ESDB6.8SM9	150	3.5	SOD923



SOD-323



SOD-923



Маломощные транзисторы

Type No.	Polarity	BV _{сво}	h _{FE} -MAX	Package
S9012	PNP	40	400	SOT23
S9013	NPN	40	400	SOT23
S9014	NPN	50	1000	SOT23
S9015	PNP	50	1000	SOT23
S8050	NPN	40	350	SOT23
S8550	PNP	40	350	SOT23
SS8050	NPN	40	400	SOT23
SS8550	PNP	40	400	SOT23
MMBT2222A	NPN	75	300	SOT23
MMBT2907	PNP	60	300	SOT23
MMBT3904	NPN	60	300	SOT23
MMBT3906	PNP	40	300	SOT23
MMBT5401	PNP	160	240	SOT23
MMBT5551	NPN	180	250	SOT23
MMBT4401	NPN	60	300	SOT23
MMBT4403	PNP	40	300	SOT23
2SA1037	PNP	60	560	SOT23
MMBTA05	NPN	60	400	SOT23
MMBTA55	PNP	60	-	SOT23
2SC2412	NPN	60	560	SOT23
BC846B	NPN	80	450	SOT23
MMBTA42	NPN	300	200	SOT23
MMBTA92	PNP	300	200	SOT23
A44	NPN	400	200	SOT23
A94	PNP	400	300	SOT23



SOT-23

Продукция компании YJ

Быстродействующие диоды

Type No.	V _{drm} (V)	V _s (V)	V _t (V)	I _t (A)	Package
P0080SB	6	25	4	2.2	SMB
P0300SB	25	40	4	2.2	SMB



SMB

分类	I _{pp} 2*10us (A)	I _{pp} 8*20us (A)	I _{pp} 10*160us (A)	I _{pp} 10*560us (A)	I _{pp} 10*1000us (A)	I _t sm 60Hz (A)	di/dt (A)
B	250	250	150	100	80	20	500

Выпрямительные диодные модули

Type No.	I _o (A)	V _{RRM} (V)	Package
MD36C18D1	36	800~1800	D1
MD60C18D1	60	800~1800	D1
MD70C18D1	70	800~1800	D1
MD100C18D1	100	800~1800	D1
MD120C18D1	120	800~1800	D1
MD165C18D2	165	800~1800	D2
MD200C18D2	200	800~1800	D2
MD30DU18DA	30	800~1800	DA
MD260C18D3	260	800~1800	D3
MD300C18D3	300	800~1800	D3
MD400C18D4	400	800~1800	D4
MD500C18D5	500	800~1800	D5
MD600C18D5	600	800~1800	D5
MD800C18D6	800	800~1800	D6
MD300U18I3	300	800~1800	I3
MD400U18I4	400	800~1800	I4



D1



D2



DA

Трёхфазные выпрямительные диодные модули

Type No.	I _o (A)	V _{RRM} (V)	Package
MD60S18M2	60	800~1800	M2
MD75S18M2	75	800~1800	M2
MD100S18M2	100	800~1800	M2
MD100S18M3	100	800~1800	M3
MD130S18M3	130	800~1800	M3
MD160S18M3	160	800~1800	M3
MD200S18M3	200	800~1800	M3
MD250S18M3	250	800~1800	M3
MD50S18M4	50	800~1800	M4
MD75S18M4	75	800~1800	M4
MD100S18M4	100	800~1800	M4
MD100S18M5	100	800~1800	M5



M2



M3



M4

Type No.	Io(A)	VRRM(V)	Package
MD130S18M5	130	800~1800	M5
MD160S18M5	160	800~1800	M5
MD200S18M5	200	800~1800	M5
MD250S18M5	250	800~1800	M5



M5

Тиристорные модули

Type No.	Io(A)	VRRM(V)	Package
MT25C16T1	25	800~1600	T1
MT40C16T1	40	800~1600	T1
MT60C16T1	60	800~1600	T1
MT90C16T1	90	800~1600	T1
MT110C16T1	110	800~1600	T1
MT130C16T2	130	800~1600	T2
MT160C16T2	160	800~1600	T2
MT200C16T2	200	800~1600	T2
MT25CB16T1	25	800~1600	T1
MT40CB16T1	40	800~1600	T1
MT60CB16T1	60	800~1600	T1
MT90CB16T1	90	800~1600	T1
MT110CB16T1	110	800~1600	T1
MT130CB16T2	130	800~1600	T2
MT160CB16T2	160	800~1600	T2
MT200CB16T2	200	800~1600	T2
MT75DT16L1	75	800~1600	L1
MT100DT16L1	100	800~1600	L1
MT150DT16L2	150	800~1600	L2
MT200DT16L2	200	800~1600	L2
MT275C18T3	275	800~1800	T3
MT330C18T4	300	800~1800	T4
MT570C18T6	570	800~1800	T6



T1



T2



L1



L2

FRD модули

Type No.	Io(A)	VRRM(V)	Package
MF200K04F3	2x100	400	F3
MF300K04F3	2x150	400	F3
MF400K04F3	2x200	400	F3
MF200K06F3	2x100	600	F3
MF300K06F3	2x150	600	F3
MF200DU12FJ	2x100	600~1200	FJ
MF200K04F4N	2x100	400	F4N
MF300K06F4N	2x150	600	F4N
MF100C12F1	100	600~1200	F1
MF100A12F1	100	600~1200	F1



F3



FJ



F4N

Продукция компании УЈ

Type No.	Io(A)	VRRM(V)	Package
MF100K12F1	100	600~1200	F1
MF300U12F2	300	600~1200	F2
MF400U12F2	400	600~1200	F2
MF100K12F2	100	600~1200	F2
MF150K12F2	150	600~1200	F2
MF200K12F2	200	600~1200	F2
MF300K12F2	300	600~1200	F2
MF100A12F2	100	600~1200	F2
MF150A12F2	150	600~1200	F2
MF200A12F2	200	600~1200	F2
MF300A12F2	300	600~1200	F2
MF100C12F2	100	600~1200	F2
MF150C12F2	150	600~1200	F2
MF200C12F2	200	600~1200	F2
MF300C12F2	300	600~1200	F2



F3



F1



F2

IGBT модули

Type No.	Io(A)	VRRM(V)	Package
MG75HF12C1	75	1200	C1
MG100HF12C1	100	1200	C1
MG150HF12C2	150	1200	C2
MG200HF12C2	200	1200	C2



C1



C2

Модули Schottky

Type No.	Io(A)	VRRM(V)	Package
MB400K01F3	2x200	100~200	F3
MB600K01F3	2x300	100~200	F3
MB800K01F3	2x400	100~200	F3
MB400K02F4N	2x200	100~200	F4N



F3

Кристаллы собственного производства

Type	Dice size(Mil)
HER GPP(EPI)	46~120
SF GPP(EPI)	46~120
UG GPP(EPI)	42~180
FR GPP(AS-CUT)	42~110
HER GPP(AS-CUT)	165~260
SF GPP(AS-CUT)	175~260
TVS GPP	46~120
TVS OJ	46~120
STD GPP(AS-CUT)	42~180
OPEN JUNCTION	42~110
AUTOMOTIVE ELECTRONICS CHIP(GPP)	165~260
AUTOMOTIVE ELECTRONICS CHIP(OJ)	175~260

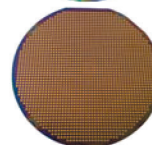
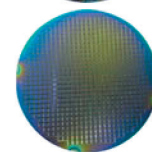
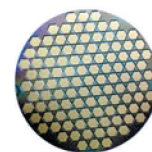

• Схемы диодов и диодных мостов

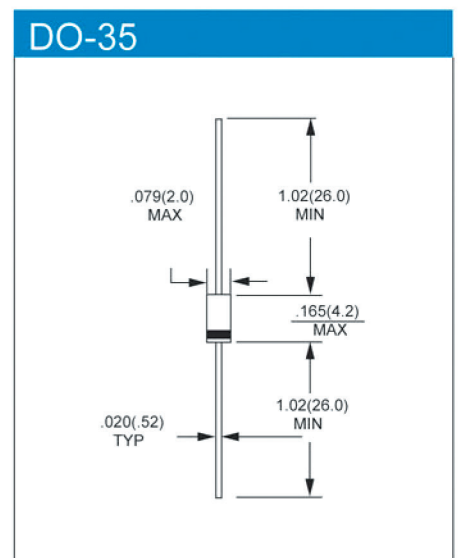
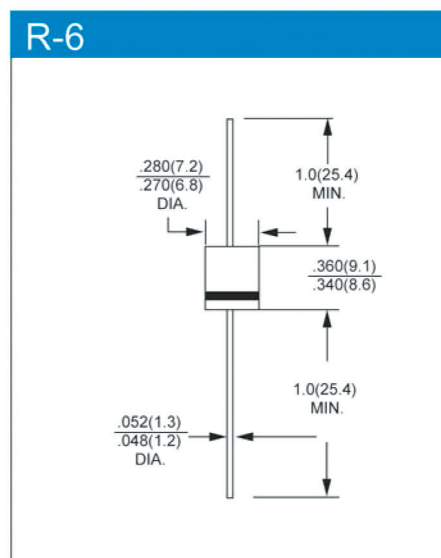
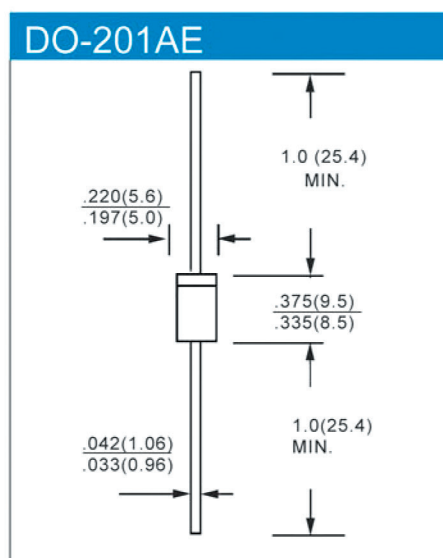
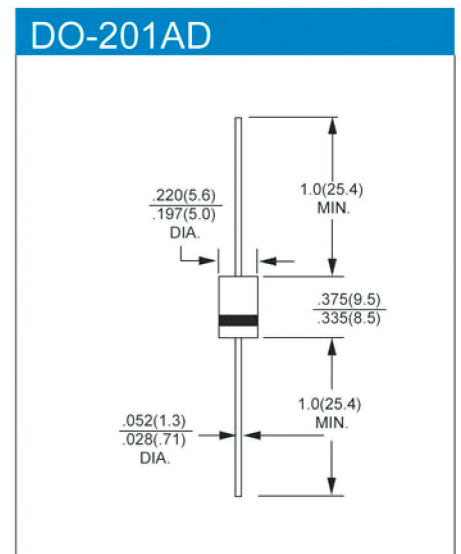
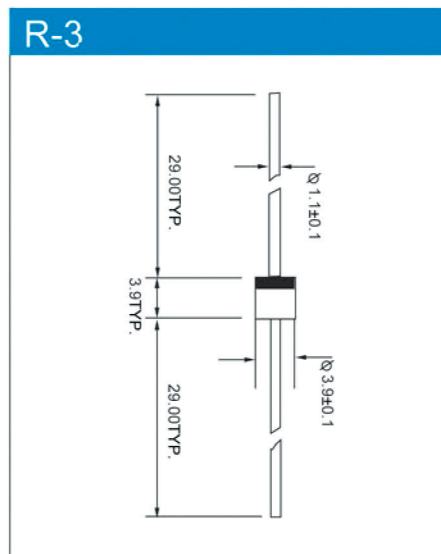
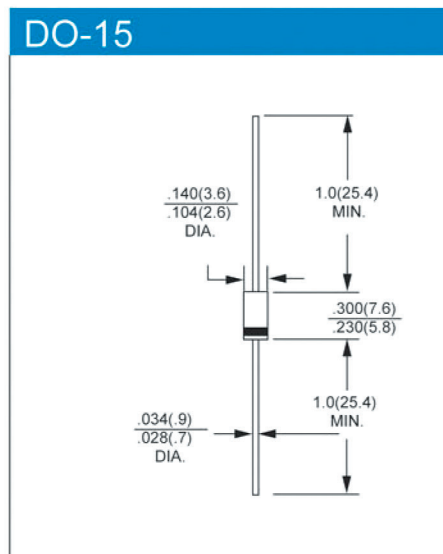
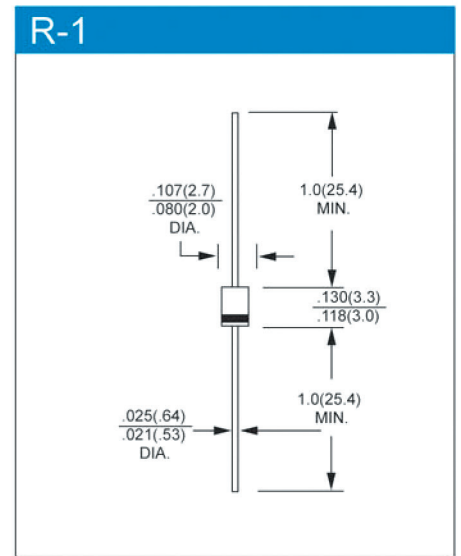
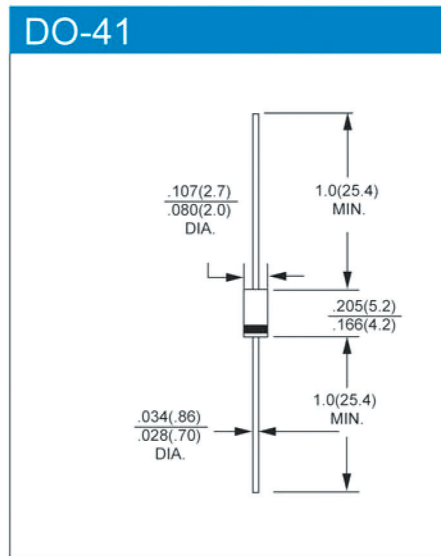
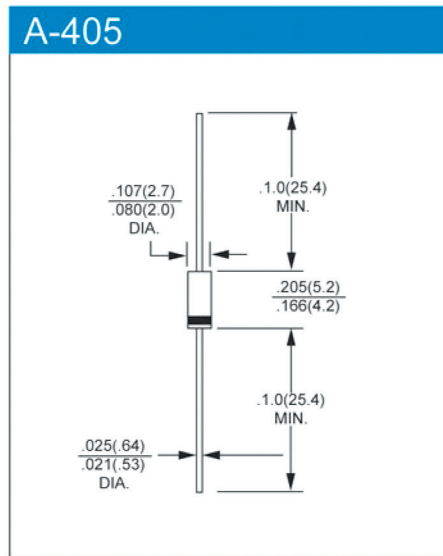

Продукция компании УЈ

MINI MELF(LL-34)

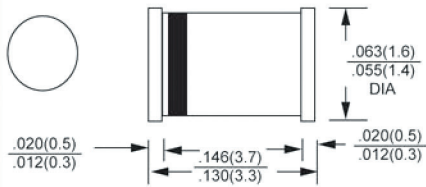

DL-41

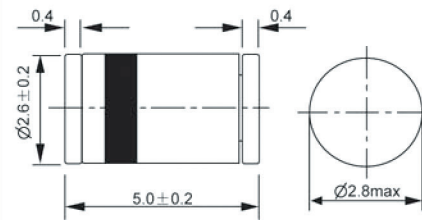

TO-277

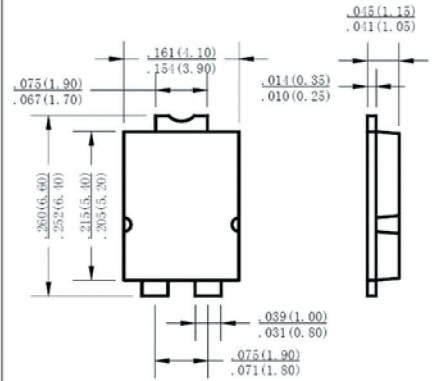

SOT-23

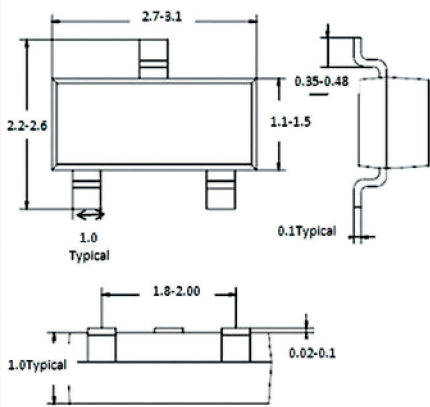

SOD-923

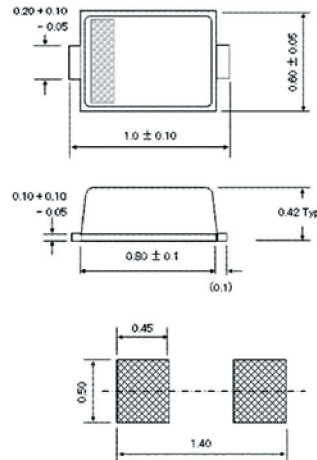

SOD-523

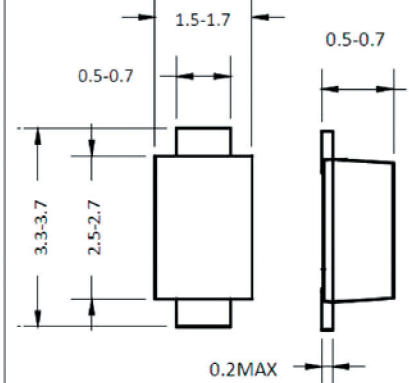

SOD-323

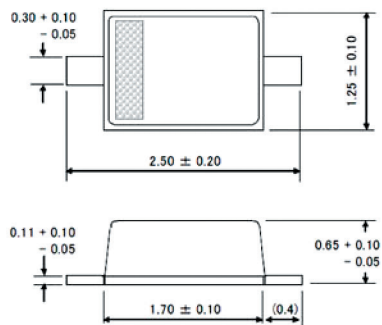

SOD-123

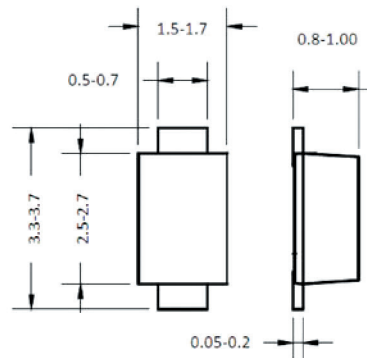

SOD-123FL

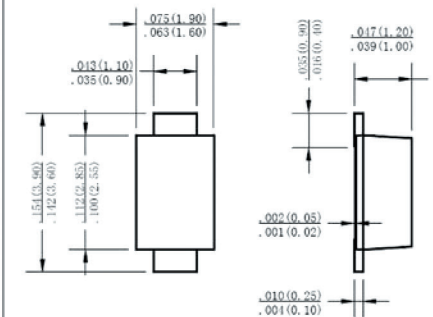

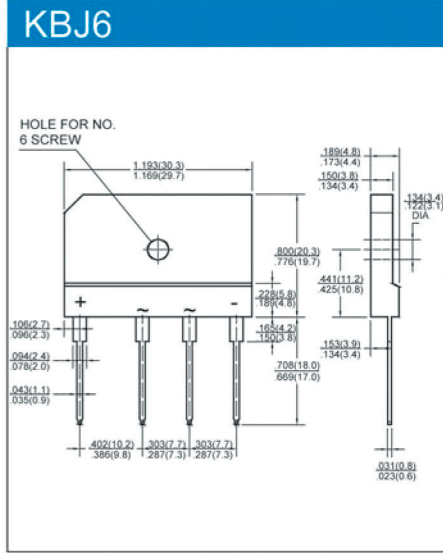
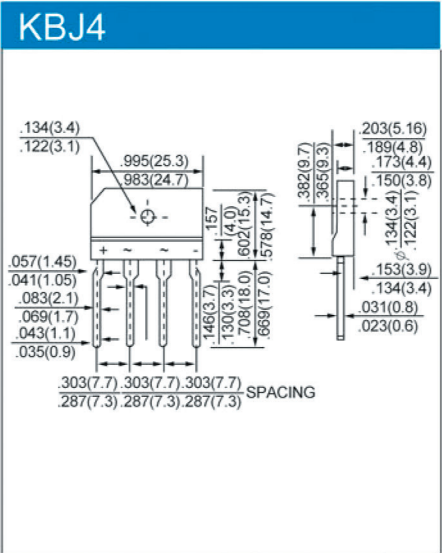
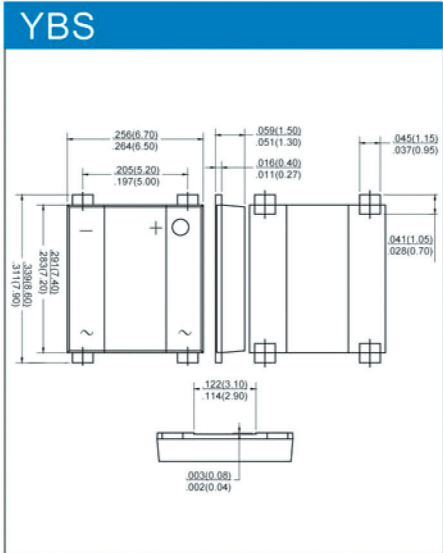
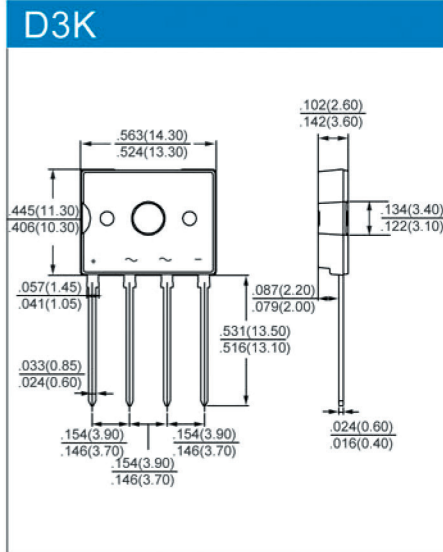
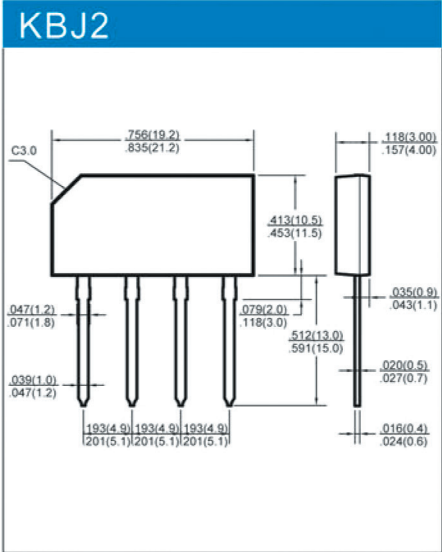
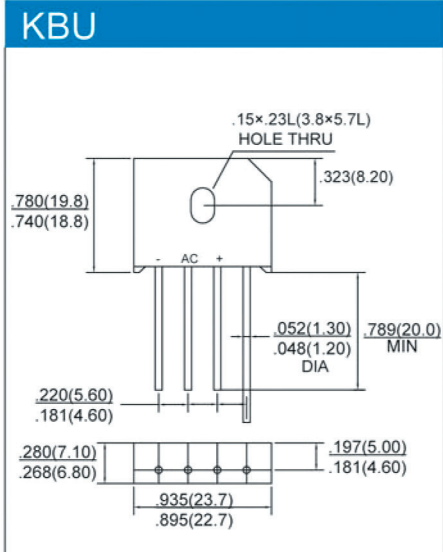
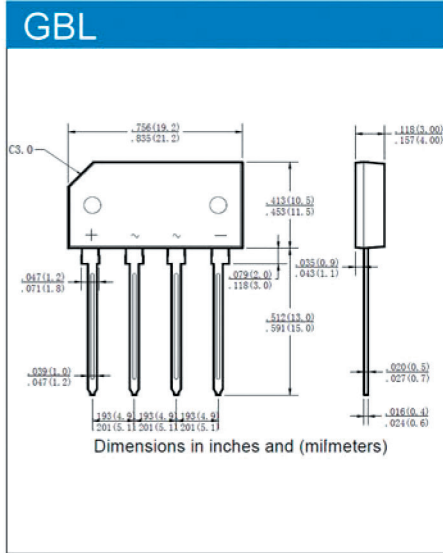
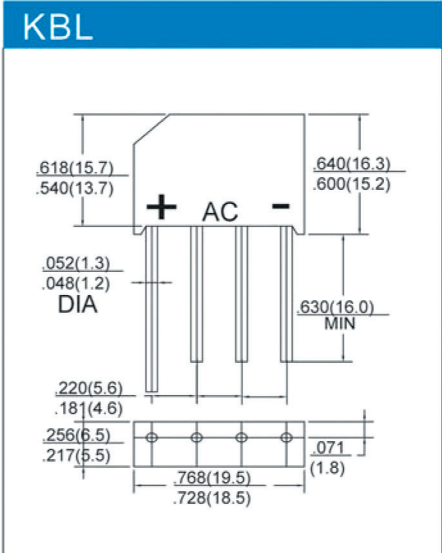
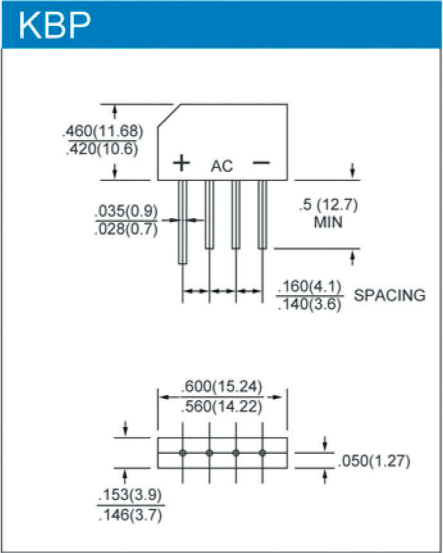

Продукция компании УЈ

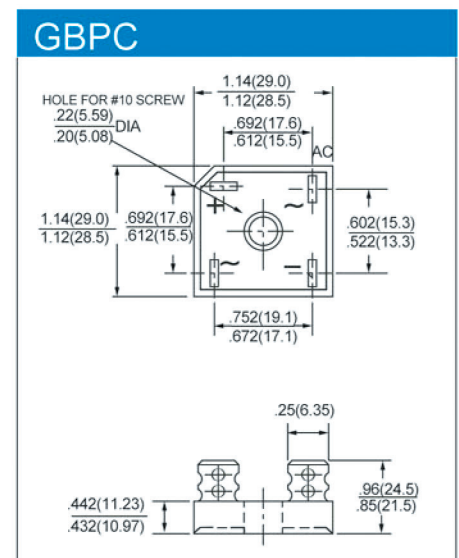
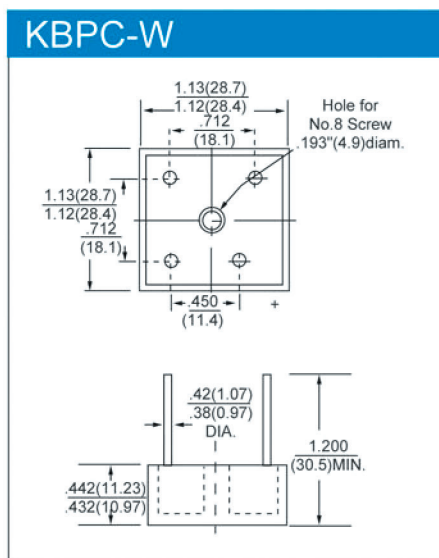
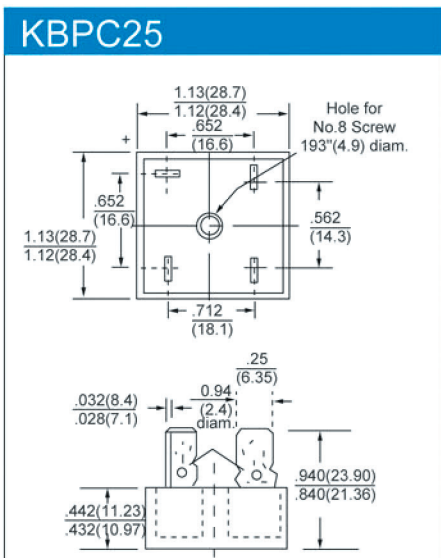
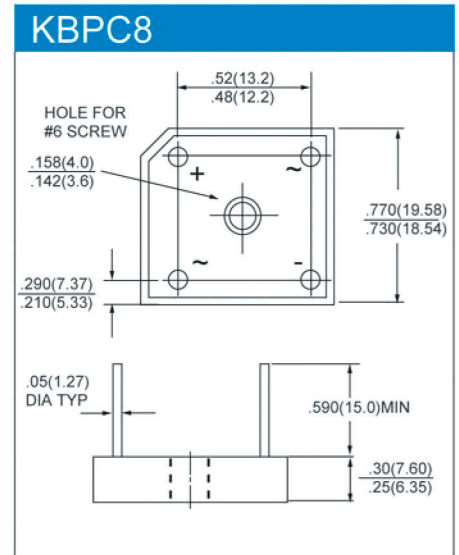
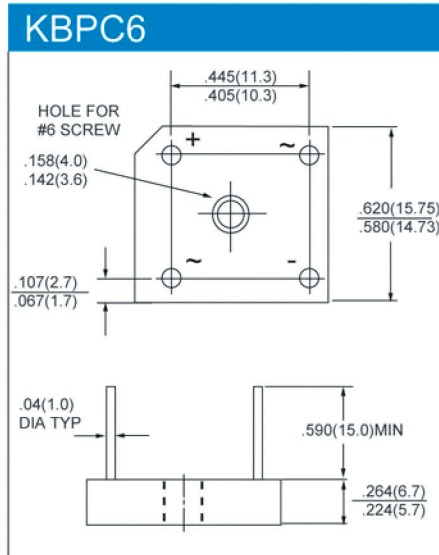
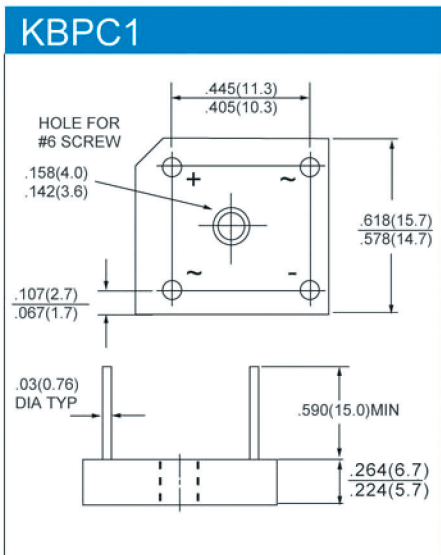
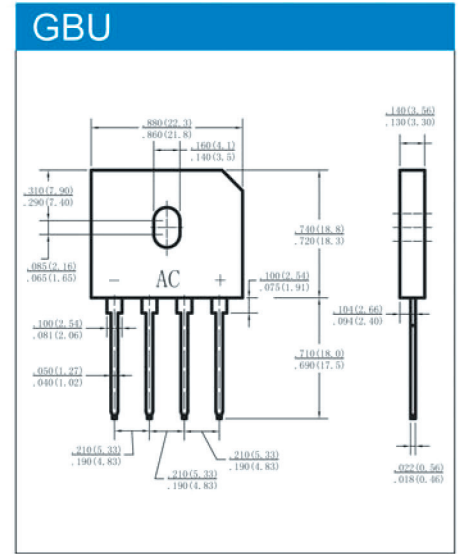
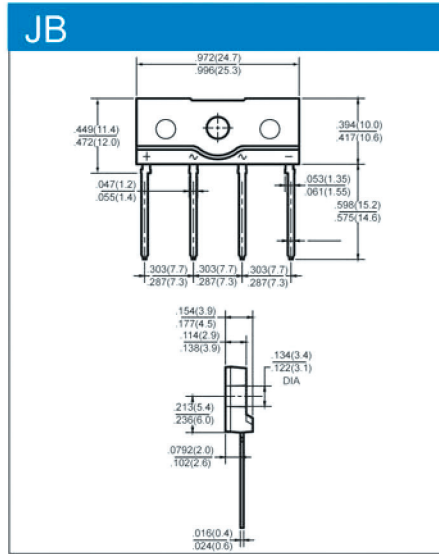
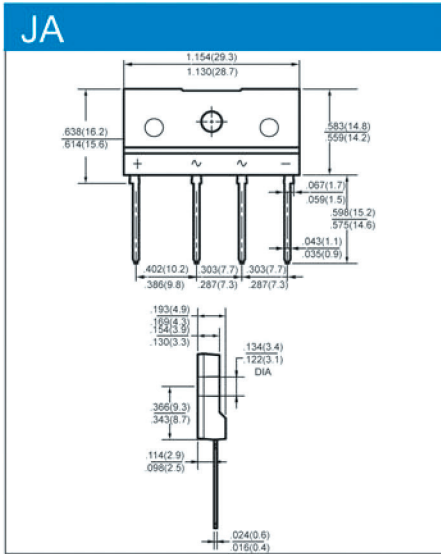

Продукция компании УЈ

Схемы диодных модулей

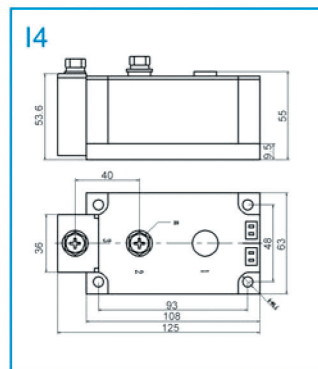
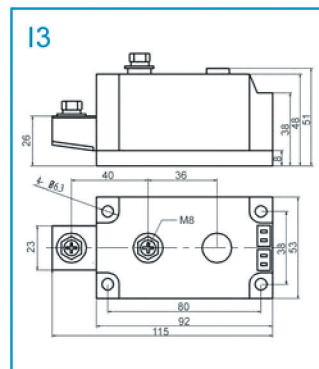
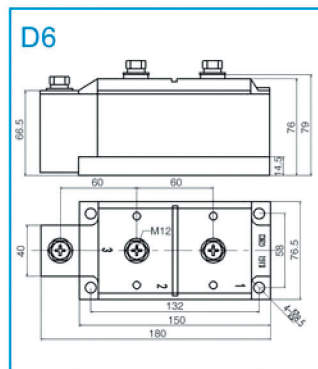
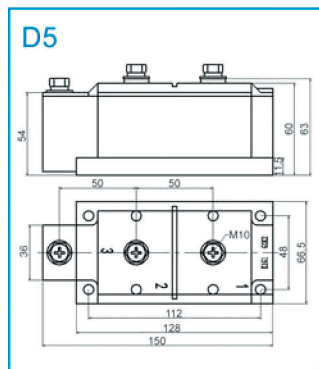
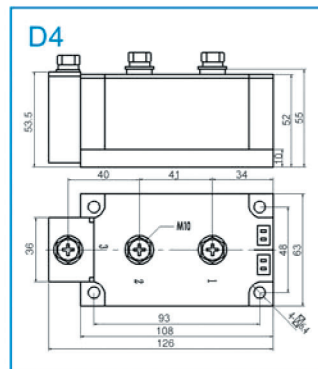
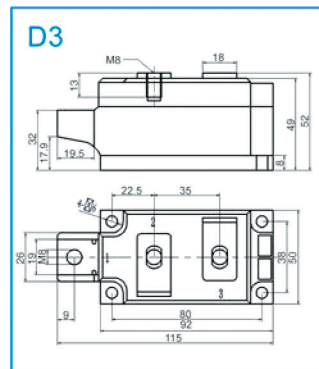
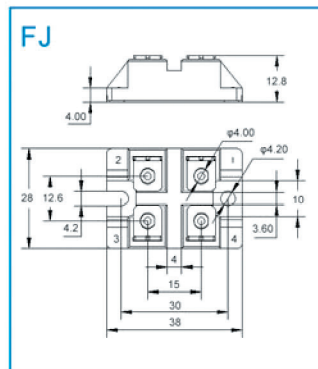
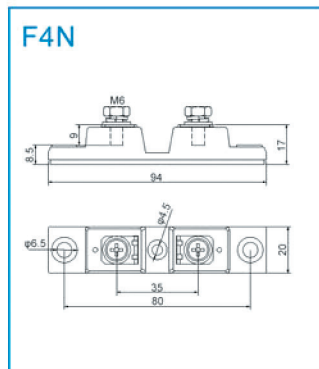
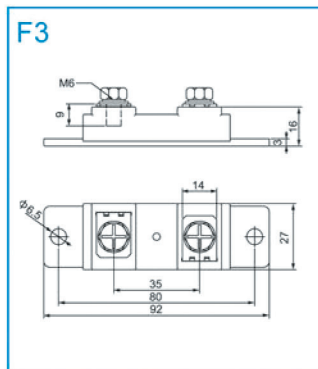
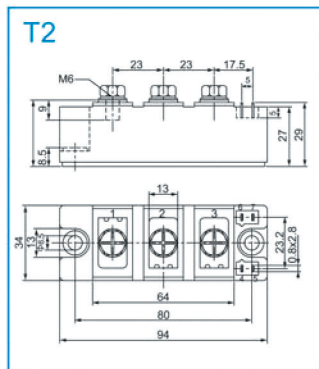
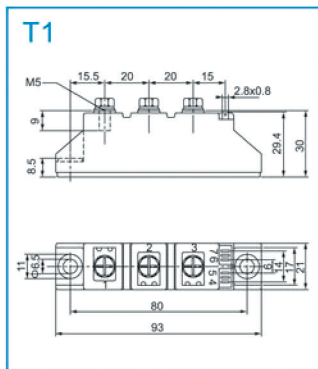
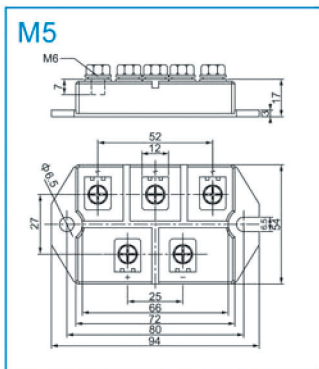
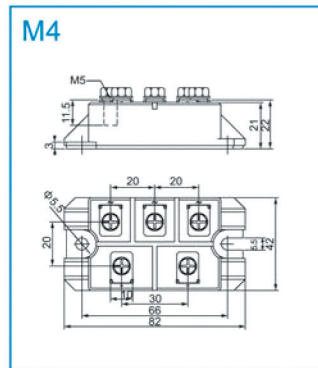
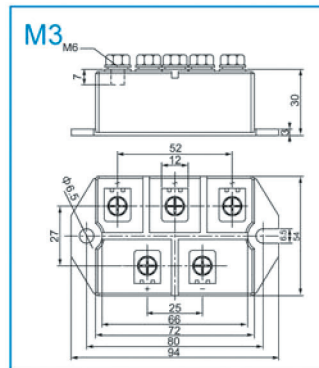
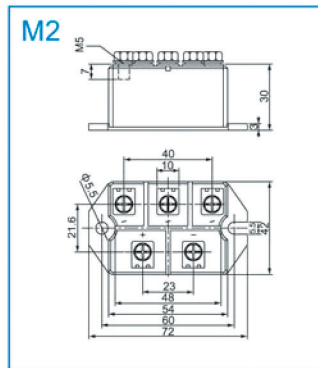
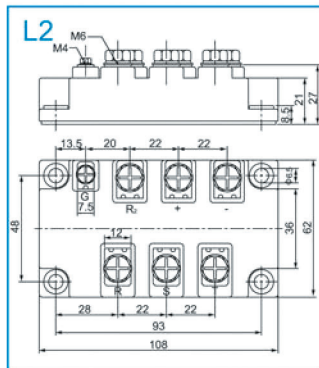

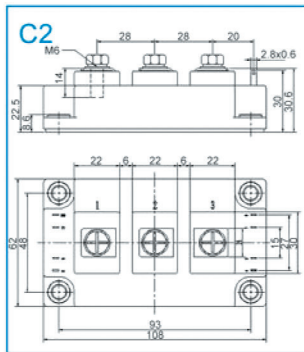
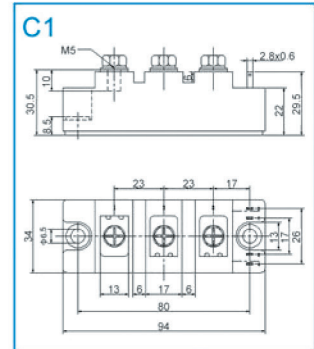
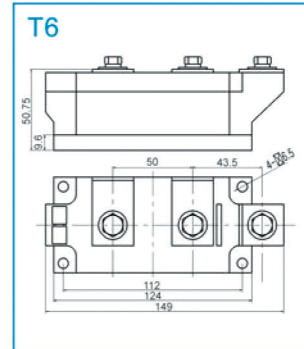
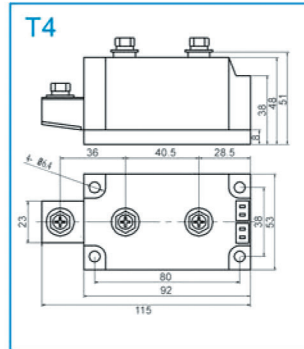
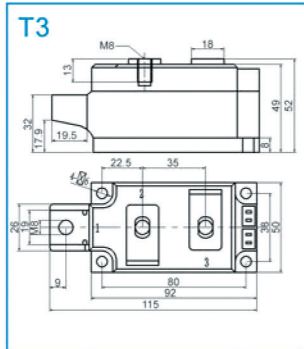

● Схемы кристаллов

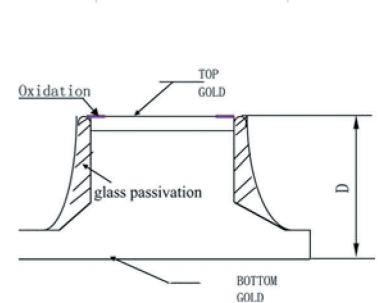
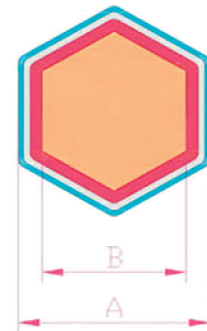
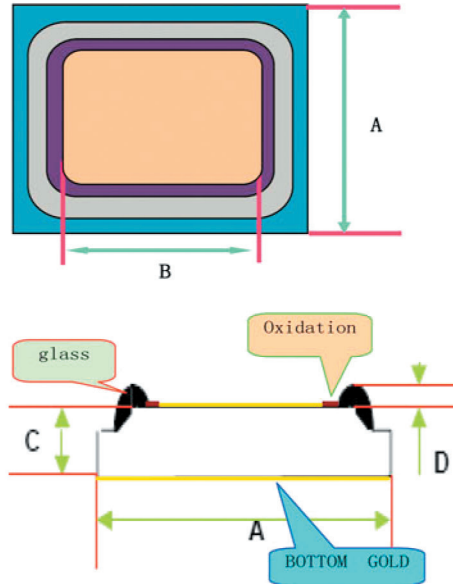
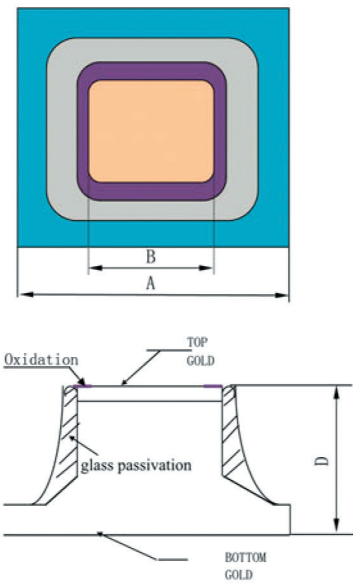

Промышленное применение и основные потребители



Клиенты компании YJ



Автомобильная электроника

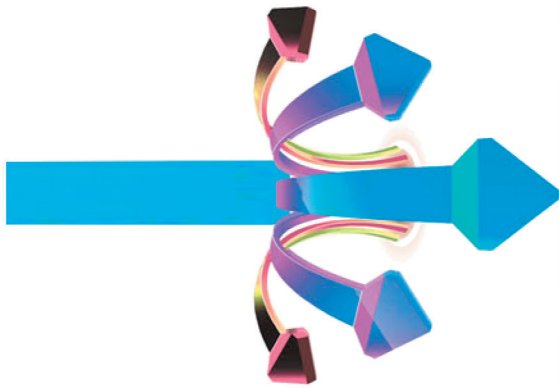

美的 Midea	Panasonic	CITIZEN Micro HumanTech
Hisense	AUX 奥克斯	PHILIPS
TOSHIBA	Joyoung 九阳	SHARP

ROEWE	Ford	BYD	
	CEELY	XUNYI	

Trinasolar 天合光能	ZJRH [®]	YINGLI SOLAR
CanadianSolar		Tyco Electronics

台达 DELTA			
加興電子 muRata			

**YANGZHOU YANGJIE
ELECTRONIC TECHNOLOGY**



Головной офис продаж
м. Молодежная
+7 (495) 97-000-99
info@platan.ru

Платан-Электроника
м. Электрозаводская,
+7 (495) 744-70-70
platan@platan.ru

Платан-Энерго
м. Беговая
+7 (495) 252 07 77
sales@platan-energo.ru

Платан-Балтика
+7 (812) 232-88-36
baltika@platan.spb.ru

Интернет-магазин
+7 (495) 97-000-99
shop@platan.ru